



218/11 Potter Street Waterloo NSW

2  2  1 

Situated in the heart of the burgeoning inner-city precinct of Waterloo, this modern light filled two-bedroom apartment seamlessly integrates comfort with modern functionality. Offering superbly styled interiors and a versatile floor plan it is ideal for low maintenance living and offers an undeniable inner-city lifestyle. Enjoy the proximity to local parks, cafés, Coles supermarket, shopping, restaurants, schools and city transport services

Price : Contact agent
View : <https://www.landmarkrealtygroup.com.au/sale/nsw/eastern-suburbs/waterloo/residential/apartment/7902753>

- * Large covered balcony for year-round entertaining
- * Open plan living and dining flows seamlessly to alfresco setting
- * Sleek stone kitchen, Stainless Steel appliances; gas cooktop.
- * Two spacious bedrooms, both with BIR's and balcony access
- * Modern tiled bathroom, internal laundry with dryer, air-con



Lee Chan
02 8221 8819



Eric Chan
02 8221 8819

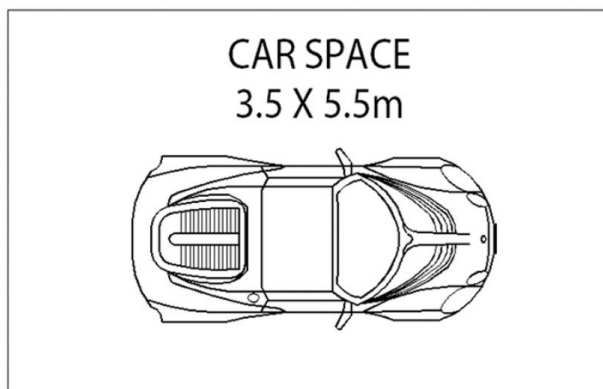
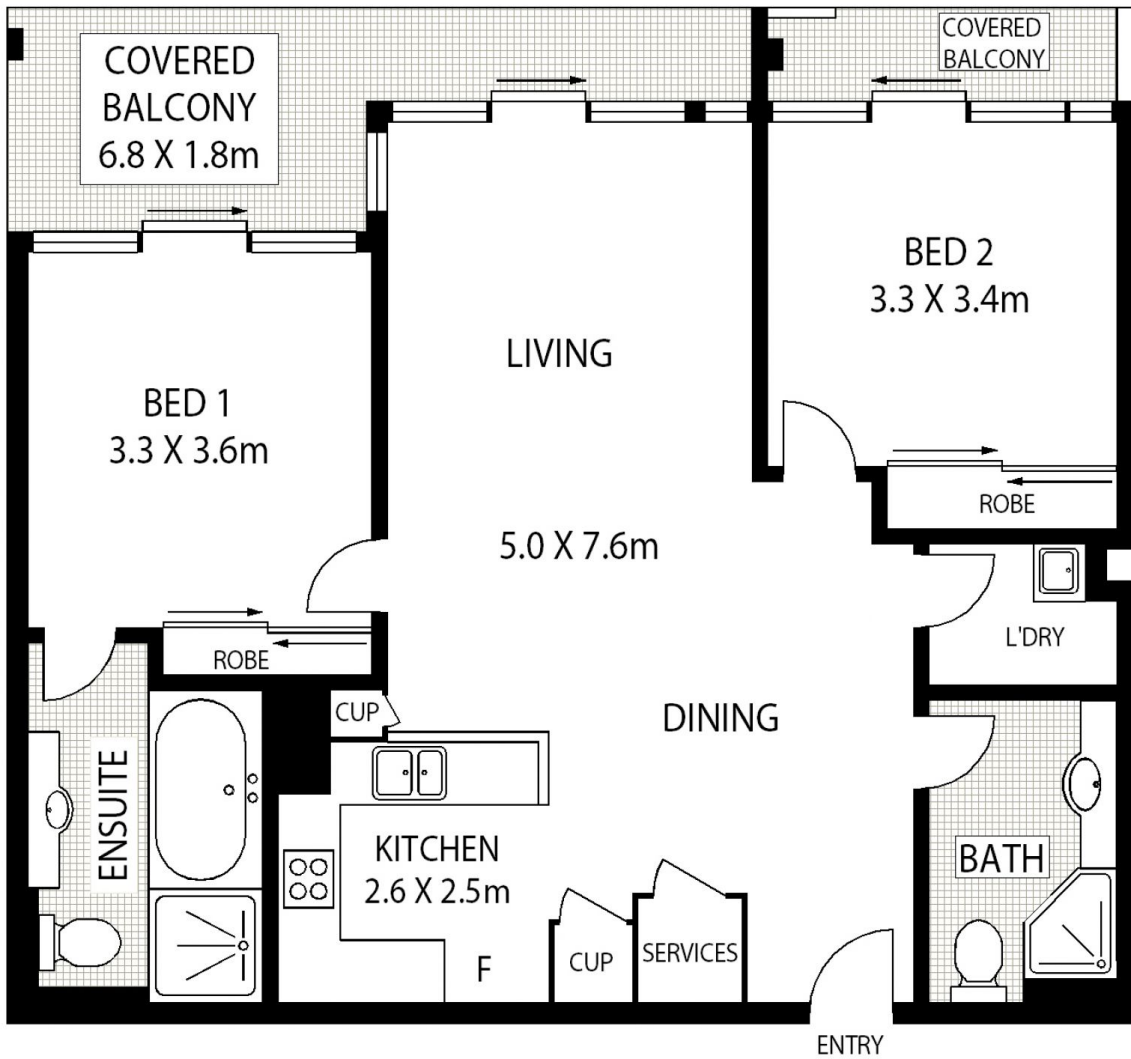

218/11 POTTER STREET

WATERLOO

AREA: 96 SQM (INCLUDING BALCONY)
TOTAL: 110 SQM (INCLUDING CAR SPACE)



Scale in metres. Indicative only. Dimensions are approximate. All information contained herein is gathered from sources we believe to be reliable. However we cannot guarantee its accuracy and interested persons should rely on their own enquiries.